



30 INCH DRUM FAN 230V
MODEL NO: CAM30B

PART NO: 3231567

OPERATION & MAINTENANCE
INSTRUCTIONS

UK
CA | CE



ORIGINAL INSTRUCTIONS

GC0725 - REV 1

INTRODUCTION

Thank you for purchasing this CLARKE 30" Drum Fan.

Before attempting to use this product, please read this manual thoroughly and follow the instructions carefully. In doing so you will ensure the safety of yourself and that of others around you, and you can look forward to your purchase giving you long and satisfactory service.

MODEL	CAM30B
Voltage:	230 V ~ (50Hz)
Ingress Protection Rating	IP20
Insulation Class	1
Fan Power Input	118.6 W
Duty Cycle	S1 (continuous)
Fan Speeds	Position 1-850 rpm / Position 2 - 919 rpm
Fan Sound Power Level	78 dB(A)
Sound Power Measured	82.4 dB(A) L _{wa}
Guaranteed Sound Level	84.9 dB L _{wa}
Maximum Fan Flow Rate	283.4 m ³ /m
Maximum Air Velocity	2.2 m/sec
Service Value	2.4 m ³ /m/W
Measurement Standard for Service Value	EU 206/2012
Dimensions (D x W x H) mm	830 x 300 x 845
Weight:	18.6 kg
Further ERP Ratings	
Standby power consumption	0.0
Seasonal electricity consumption	38.0 kWh/a

ELECTRICAL CONNECTIONS



WARNING! READ THESE ELECTRICAL SAFETY INSTRUCTIONS THOROUGHLY BEFORE CONNECTING THE PRODUCT TO THE MAINS SUPPLY.

Before switching the product on, make sure that the voltage of your electricity supply is the same as that indicated on the rating plate. This product is designed to operate on 230VAC 50Hz. Connecting it to any other power source may cause damage.

This product may be fitted with a non-rewireable plug. If it is necessary to change the fuse in the plug, the fuse cover must be refitted. If the fuse cover becomes lost or damaged, the plug must not be used until a suitable replacement is obtained.

If the plug has to be changed because it is not suitable for your socket, or due to damage, it should be cut off and a replacement fitted, following the wiring instructions shown below. The old plug must be disposed of safely, as insertion into a mains socket could cause an electrical hazard.

If the colours of the wires in the power cable of this product do not correspond with the markings on the terminals of your plug, proceed as follows.

- The **Blue** wire must be connected to the terminal marked **N** or coloured **Black**.
- The **Brown** wire must be connected to the terminal marked **L** or coloured **Red**.
- The **Yellow and Green** wire must be connected to the terminal marked **E** or  or coloured **Green**.

Plug must be BS1363/A approved.

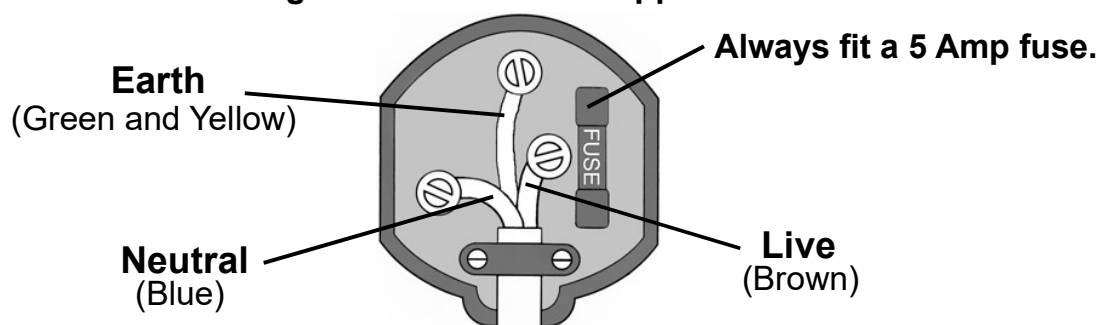

Ensure that the outer sheath of the cable is firmly held by the clamp

We strongly recommend that this machine is connected to the mains supply via a Residual Current Device (RCD)

If in any doubt, consult a qualified electrician. **DO NOT** attempt any repairs yourself.

SAFETY PRECAUTIONS

1. **ALWAYS** read the manual before use.
2. Suitable for indoor use only.
3. Avoid using in dusty environments.
4. **DO NOT** use in environments containing chemical fumes etc.
5. **DO NOT** use as an extractor fan.
6. **DO NOT** use in areas of high humidity/water vapour, i.e. bathrooms etc.
7. **DO NOT** connect the fan to duct system.
8. **DO NOT** cover the fan with clothing or any material that will restrict free airflow through the fan.
9. **NEVER** touch the blades with your hand or any loose object.
10. **ALWAYS** unplug the fan before moving it or performing maintenance.
11. **DO NOT** touch the fan when your hands are wet.
12. **ALWAYS** unplug the fan when it is not in use.
13. **NEVER** unplug the fan by holding the cable. Unplug by holding the plug.
14. **NEVER** use the fan if the cable or plug are damaged.
15. **NEVER** use the fan close to fires.
16. **DO NOT** use this fan with any solid-state speed control device to reduce the risk of fire or electric shock.
17. Those who are not qualified electricians should not disassemble or repair this product.

ENVIRONMENTAL RECYCLING POLICY



Through purchase of this product, the customer is taking on the obligation to deal with the WEEE in accordance with the WEEE regulations in relation to the treatment, recycling & recovery and environmentally sound disposal of the WEEE.

In effect, this means that this product must not be disposed of with general household waste. It must be disposed of according to the laws governing Waste Electrical and Electronic Equipment (WEEE) at a recognised disposal facility.

OPERATION

Turn the switch on the speed regulator to select the fan speed required.

	CAM30B
Position 1	850 RPM
Position 2	919 RPM

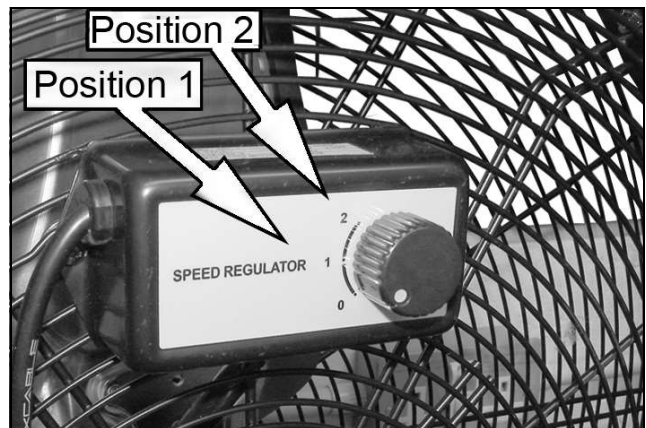

MAINTENANCE



WARNING: NEVER OPERATE THE FAN WITH THE FRONT OR REAR GUARDS REMOVED.

Have any repairs carried out by a suitably qualified person.

- The motor bearings are permanently sealed for life and do not require any additional lubrication.

If the fan has been operating for long periods in a very dusty environment, the blades and motor assembly may eventually require cleaning.

1. Disconnect the power cable from the power supply.
2. Unscrew the front guard and lift it away carefully.
3. Wipe the fan blades with dry cloth and remove any dust from the motor assembly with a soft paintbrush, vacuum cleaner or jet of compressed air.



- Always wear suitable eye protection when using compressed air.
- Never use polish or any corrosive liquid that will damage the surface finish.

4. Replace the guard securely before use.

COMPONENT PARTS

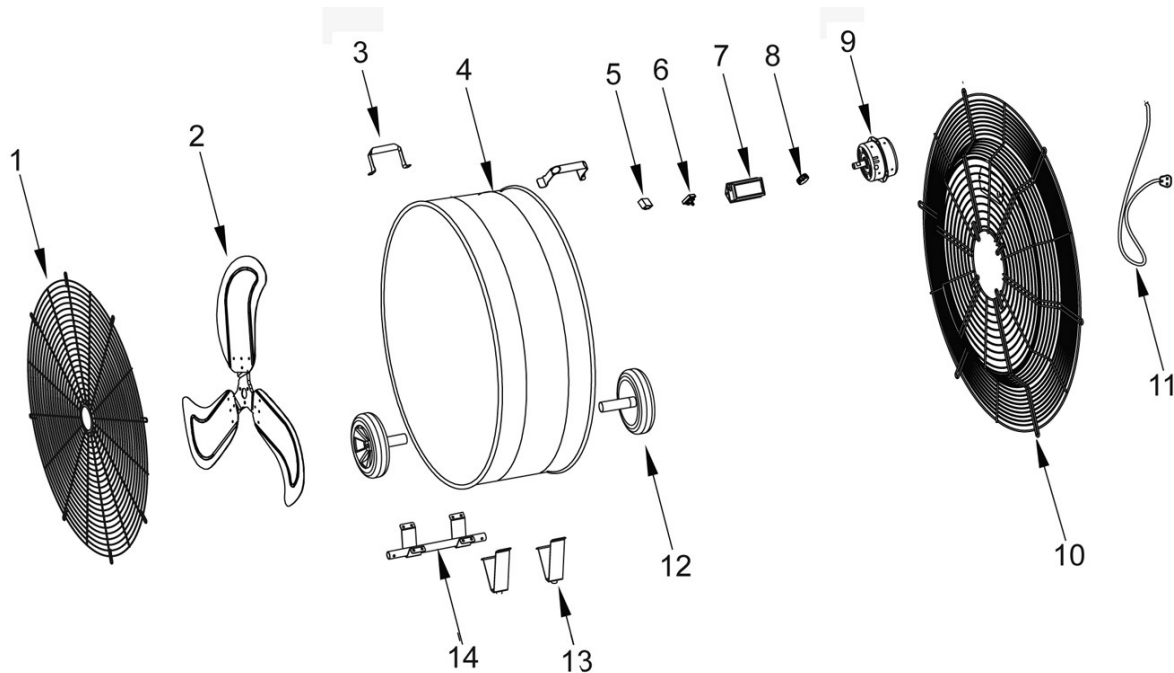

No	DESCRIPTION
1	Front Grill
2	Blade Assembly
3	Handle
4.	Drum Body
5	Capacitor
6	Switch
7	Switch Box

No	DESCRIPTION
8	Switch Knob
9	Fan Motor
10	Rear Grill
11	Power Cable
12	Wheel & Stub Axle
13	Feet
14	Long Wheel Shaft

GUARANTEE

This product is guaranteed against faulty manufacture for a period of 12 months from the date of purchase. Please keep your receipt which will be required as proof of purchase.

This guarantee is invalid if the product is found to have been abused or tampered with in any way, or not used for its intended purpose.

Faulty goods should be returned to their place of purchase, no product can be returned to us without prior permission. This guarantee does not effect your statutory rights.

DECLARATIONS OF CONFORMITY



Fitzwilliam Hall, Fitzwilliam Place, Dublin 2

DECLARATION OF CONFORMITY

This is an important document and should be retained.

We hereby declare that this product(s) complies with the following legislation:

- 2009/125/EC Ecodesign Directive
- 2014/30/EU Electromagnetic Compatibility Directive
- 2014/35/EU Low Voltage Directive
- 2011/65/EU Restriction of Hazardous Substances (RoHS) Directive

The following standards have been applied to the product(s):

- EN 60335-1:2012+A11:2014+A13:2017+A1:2019+A2:2019+A14:2019+A15:2021, IEC 62321-2:2021,
- EN 60335-2-80:2003+A1:2004+A2:2009, EN 61000-3-3:2013+A1:2019+A2:2021, IEC 62321-4:2017,
- EN IEC 61000-3-2:2019+A1:2021, EN 60704-1:2010+A11:2012, IEC 62321-5:2013, EN 62233:2008,
- IEC 62321-7-1:2015, IEC 62321-7-2:2017, EN 60704-2-7:1998, IEC 62321-6:2015, EN 50564:2011,
- IEC 60879:1986/COR1:1992, EN IEC 55014-1:2021, EN IEC 55014-2:2021, IEC 62321-3-1:2013,
- IEC 62321-8:2017

The technical documentation required to demonstrate that the product(s) meet(s) the requirement(s) of the aforementioned legislation has been compiled and is available for inspection by the relevant enforcement authorities.

The CE mark was first applied in: 2011

Product Description: Drum Fan
Model Number(s): CAM30B
Serial/Batch Number: Refer to product/packaging label
Date of issue: 04/07/2025
Signed: 

J.A. Clarke
Director

CAM30B CE Clarke DOC 070425

Page 1 of 1



Hemmill Street, Epping, Essex, CM16 4LG

DECLARATION OF CONFORMITY

This is an important document and should be retained.

We hereby declare that this product(s) complies with the following legislation:

- 2009/125/EC Ecodesign Directive
- 2014/30/EU Electromagnetic Compatibility Directive
- 2014/35/EU Low Voltage Directive
- 2011/65/EU Restriction of Hazardous Substances (RoHS) Directive

The following standards have been applied to the product(s):

- EN 60335-1:2012+A11:2014+A13:2017+A1:2019+A2:2019+A14:2019+A15:2021, IEC 62321-2:2021,
- EN 60335-2-80:2003+A1:2004+A2:2009, EN 61000-3-3:2013+A1:2019+A2:2021, IEC 62321-4:2017,
- EN IEC 61000-3-2:2019+A1:2021, EN 60704-1:2010+A11:2012, IEC 62321-5:2013, EN 62233:2008,
- IEC 62321-7-1:2015, IEC 62321-7-2:2017, EN 60704-2-7:1998, IEC 62321-6:2015, EN 50564:2011,
- IEC 60879:1986/COR1:1992, EN IEC 55014-1:2021, EN IEC 55014-2:2021, IEC 62321-3-1:2013,
- IEC 62321-8:2017

The technical documentation required to demonstrate that the product(s) meet(s) the requirement(s) of the aforementioned legislation has been compiled and is available for inspection by the relevant enforcement authorities.

The UKCA mark was first applied in: 2021

Product Description: Drum Fan
Model Number(s): CAM30B
Serial/Batch Number: Refer to product/packaging label
Date of issue: 04/07/2025
Signed: 

J.A. Clarke
Director

CAM30B UKCA Clarke DOC 070425

Page 1 of 1

A SELECTION FROM THE VAST RANGE OF

Clarke®

QUALITY PRODUCTS



AIR COMPRESSORS
From DIY to industrial, Plus air tools,
spray guns and accessories.

GENERATORS
Prime duty or emergency standby
for business, home and leisure.

POWER WASHERS
Hot and cold, electric and engine
driven - we have what you need

WELDERS
Mig, Arc, Tig and Spot.
From DIY to auto/industrial.

METALWORKING
Drills, grinders and saws for DIY
and professional use.

WOODWORKING
Saws, sanders, lathes, mortisers
and dust extraction.

HYDRAULICS
Cranes, body repair kits,
transmission jacks for all types of
workshop use.

WATER PUMPS
Submersible, electric and engine driven
for DIY, agriculture and industry.

POWERTOOLS
Angle grinders, cordless drill sets,
saws and sanders.

STARTERS/CHARGERS
All sizes for car and commercial use.



PARTS & SERVICE:
0208 988 7400

Parts Enquiries
Parts@clarkeinternational.com

Servicing & Technical Enquiries
Service@clarkeinternational.com

SALES: UK 01992 565333 or Export 00 44 (0)1992 565335

Clarke INTERNATIONAL Hemnall Street, Epping, Essex CM16 4LG
www.clarkeinternational.com